



SERVICE INSTRUCTIONS

7149-4 Series

Model 7149-4 Series Hand Operated Bucket Pumps

The 7149-4 series of Alemite Bucket Pumps are designed to deliver lubricant to bearings of off-the-road equipment with various types of grease fittings.

These pumps develop from 2500 to 5000 psi, delivering about 1/3 ounce per stroke with the lever attached to the pump in the normal center position. The lubricant container has a capacity of 35 pounds.

See the chart below for the various models in the 7149-4 series, which are covered by the instruction sheet.



Figure 1: Model 7149-A4 Bucket Pump

MODEL CHART

MODEL	PAGE	COMPONENTS IN ADDITION TO 7149-4 BUCKET PUMP
7149-A4	2-3	322434 Hose Assembly (Figure 4)
7149-C4	4	6617-G Hydraulic Coupler and Hose Assembly (Figure 5)
7149-D4	4	317854-5F Hose (Figure 6) 43706 Angle Body A-112 Bushing (Figures 3, 6, and 12) A-336 Pin-Type Fitting 50491 Coupler 171134 Plug Button

Alemite, LLC
167 Rowland Drive, Johnson City Tennessee 37601
www.alemite.com

Copyright © 2006 by Alemite, LLC

This document contains confidential information that is the property of Alemite, LLC and is not to be copied, used, or disclosed to others without express written permission.

7149-E4	4	6616-G A-1188 171134	Hose and Coupler Assembly (Figure 7) Button Head Fitting Plug Button
7149-F4	5	6615-G 171134 322108	Hose and Coupler Assembly (Figure 8) Plug Button Button Head Fitting
7149-H4	5	322434 322630	Hose Assembly (Figures 4, 9) Loader Kit
7149-A4P	6	322439 7149-4P	Hose Assembly (Figure10)

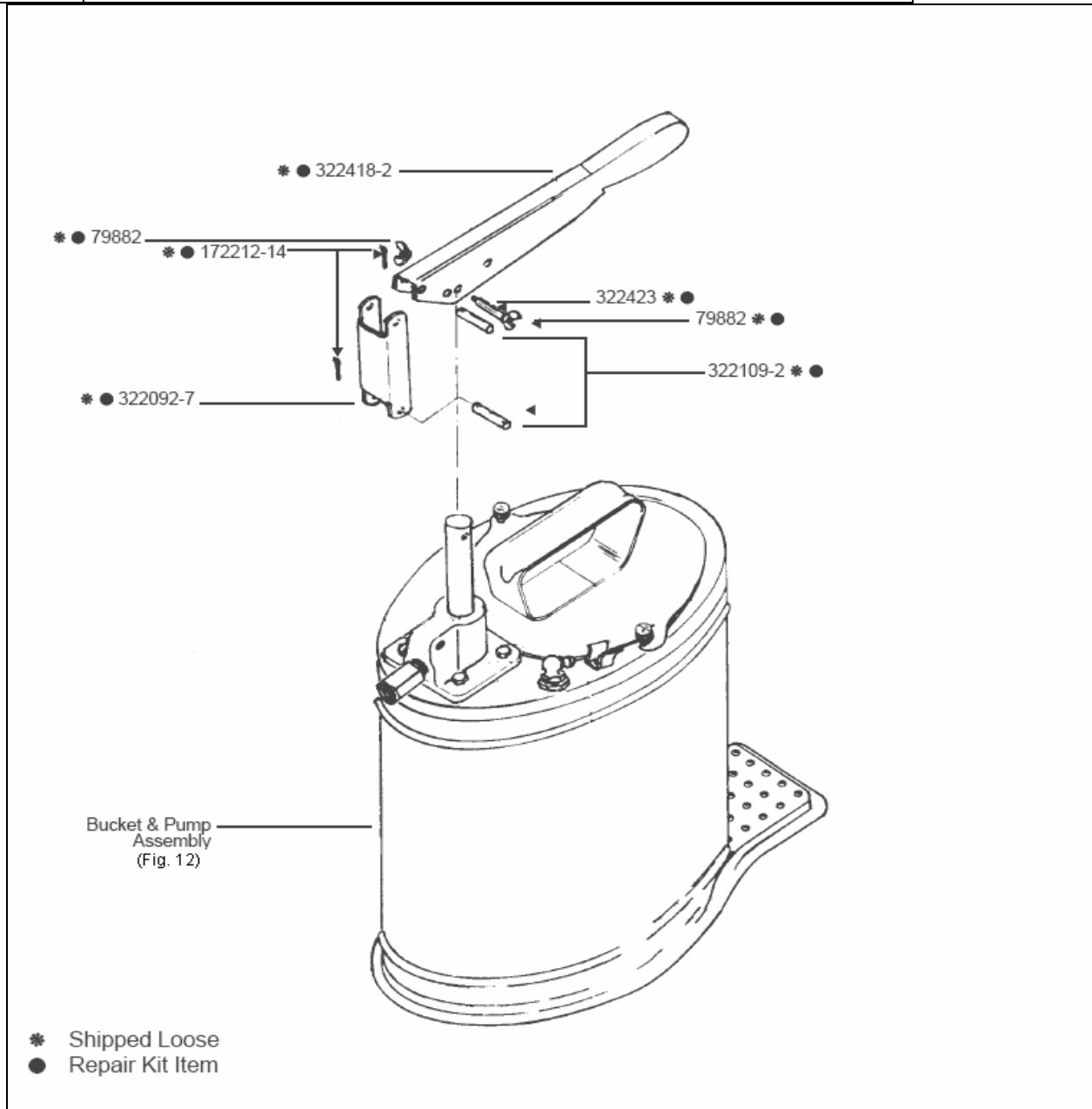

Figure 2: Components of Model 7149-A4 Bucket Pump

ASSEMBLY

To assemble the basic Bucket Pump Model 7149-4, proceed as follows (see **Figure 2**):

1. Attach link 322092-7 to pump body 322115-6 (see **Figure 12**) with pin 322109-2 and secure with cotter pin 172212-14.
2. Attach lever 322418-2 to link with pin and secure with cotter pin.
3. Attach lever to pump plunger with stud 322428 and wing nuts 79882 through one of the three holes provided (see adjustment instructions on **page 7**).
4. See further instructions for specific model.

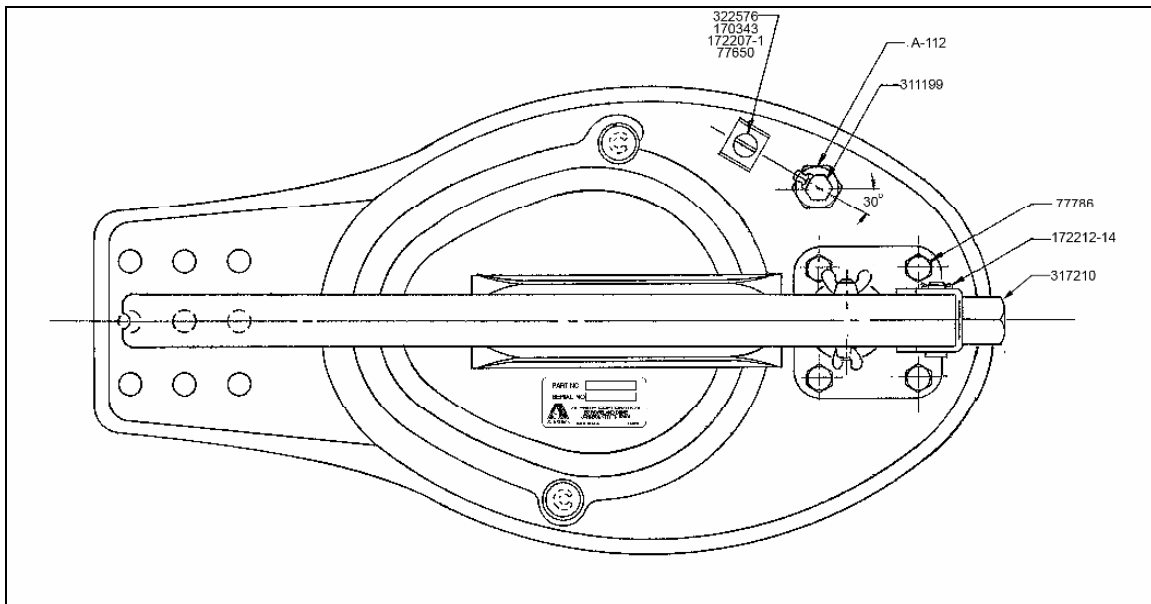

Figure 3: Model 7149-4 Bucket Pump

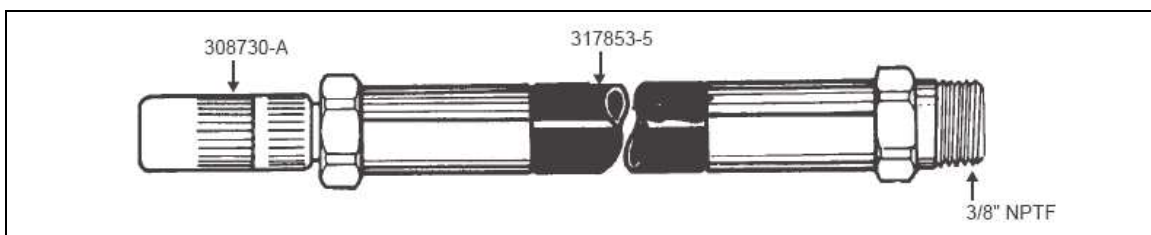

Figure 4: Model 322434 Hose Assembly (for Models 7149-A4 and 7149-H4)

MODEL 7149-A4 (Figures 3 and 4):

Thread hose assembly 322434 into check valve 317210 and tighten.

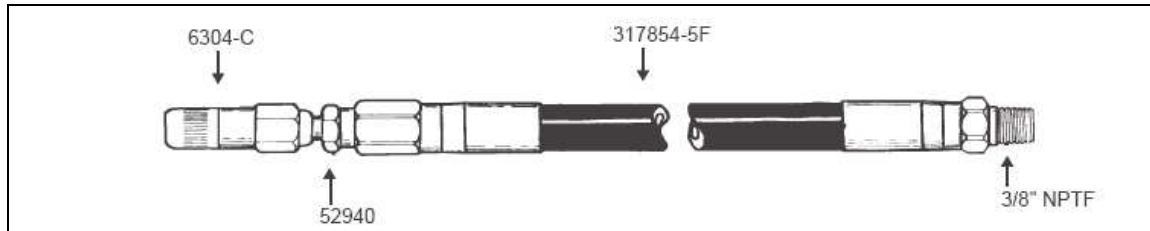

Figure 5: Model 6617-G Hydraulic Coupler and Hose Assembly (for Model 7149-C4)

MODEL 7149-C4 (Figure 5):

Thread hydraulic coupler and hose assembly 6617-G into check valve 317210 and tighten.

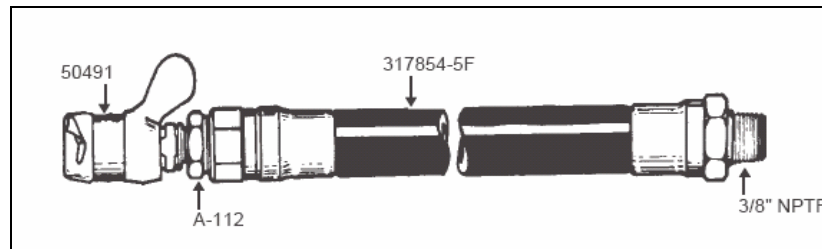

Figure 6: Hose and Coupling Assembly (for Model 7149-D4)

MODEL 7149-D4 (Figures 3 and 6):

1. Unthread the 1/8" NPT hydraulic fitting 311199 from bushing A-112 (**Figure 3**). Thread angle body 43706 into bushing and pin type fitting A-336 into angle body.
2. Remove hose clip 322576, screw 170343, lock washer 172207-1 and nut 77650 from container and replace with plug button 171134.
3. Assemble hose 317854-5F, bushing A-112 and coupling assembly 50491 (**Figure 6**). Screw hose and coupling assembly into check valve 317210 and tighten.

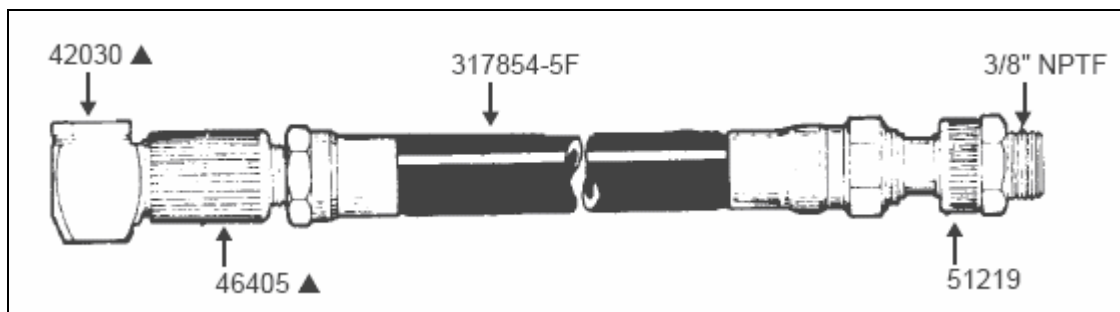

Figure 7: Model 6616-G Hose and Coupling Assembly (for Model 7149-E4)

MODEL 7149-E4 (Figure 7):

1. Remove hose clip 322576, screw 170343, lockwasher 172207-1 and nut 76650 from container and replace with plug button 171134.
2. Unthread bushing A-112 with hydraulic fitting 311199 from container and replace with button head fitting body A-1188.
3. Thread hose and coupler assembly 6616-G into check valve 317210 and tighten.

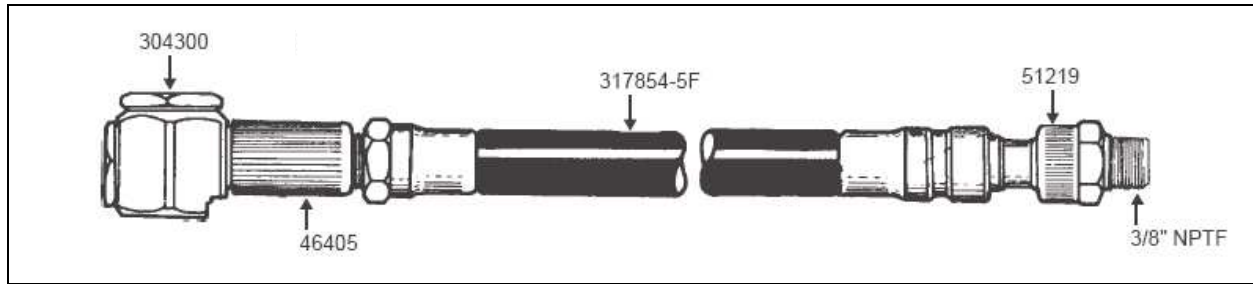

Figure 8: Model 6615-G Hose and Giant Coupler Assembly (for Model 7149-F4)

MODEL 7149-F4 (Figures 3 and 8):

1. Unthread the bushing A-112 and hydraulic fitting 311199 from container and replace with button head fitting plug 322108.
2. Remove hose clip 322576, screw 170343, lock washer 172207-1 and nut 77650 from container and replace with plug button 171134.
3. Thread hose and coupler assembly 6615-G into check valve 317210.

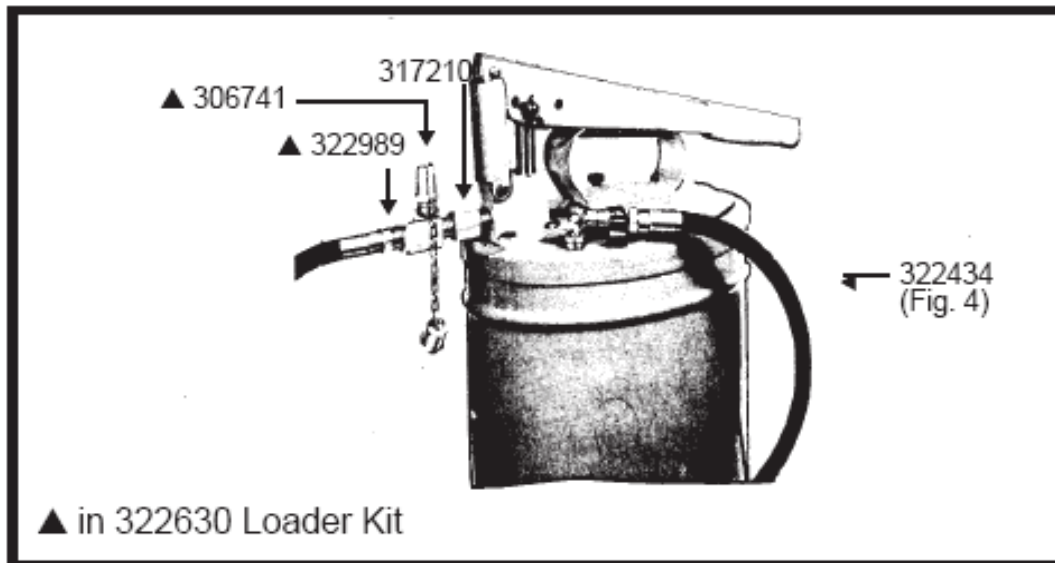

Figure 9: Model 7149-H4 Bucket Pump

MODEL 7149-H4 (Figures 4 and 9):

1. Thread loader adapter 322989 into check valve 317210.
2. Thread loader valve 306741 into loader adapter.
3. Thread hose assembly 322434 into loader adapter.

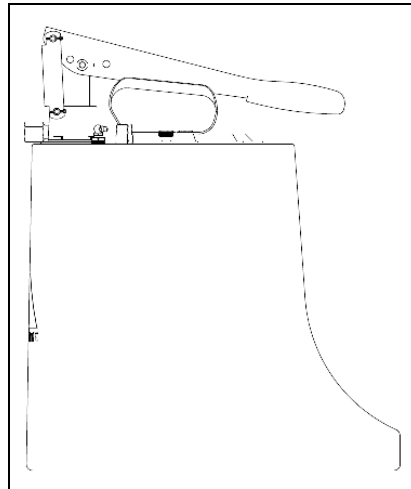

Figure 10: Model 7149-A4P

PARTS LIST - Model 7149-A4P Bucket Pump (Figure 10):

Part No.	Description	Quantity
7149-4P	Bucket Pump Assembly	1
308730-A	Hydraulic Coupler	1
317853-5	Hose	1
322434	Hose Assembly	1

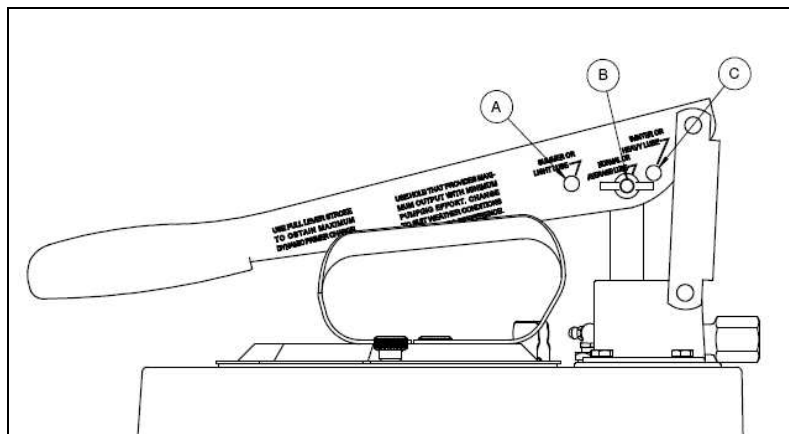

Figure 11: Lever Positions

OPERATION

TO FILL CONTAINER:

1. Raise lever and wipe off tip of container.
2. Loosen knurled thumb screws and slide cover to one side.
3. Fill container with lubricant, being careful that no air pockets are formed.

TO USE:

1. Check condition of hose and check to see that all connections are secure.

2. ADJUSTMENT INSTRUCTIONS:

Set lever at appropriate position (**Figure 11**)

- a. for lightweight lubricants and warm temperatures.
- b. for lubricants of medium thickness.
- c. for cold weather and/or thick lubricants.

(To change positions, remove wing nut 79882 and slide pin 322423, with the wing nut still attached, into alternate hole.)

2. Wipe fitting and coupler and place coupler on fitting.
3. Pump lubricant into bearing. Remove coupler.
4. Wrap hose around bucket and attach coupler to fitting on top of container. On most models, this fitting serves as a pressure release and allows excess lubricant to run back into the container.

IF PUMP FAILS TO BUILD UP PRESSURE OR DELIVER LUBRICANT:

1. Check if lubricant level is low or if air pockets have developed, allowing air to enter pump.
2. Check hose and connection for leaks.
3. If pressure still fails to build up, overhaul pump with Major Repair Kit 398724 or replace.

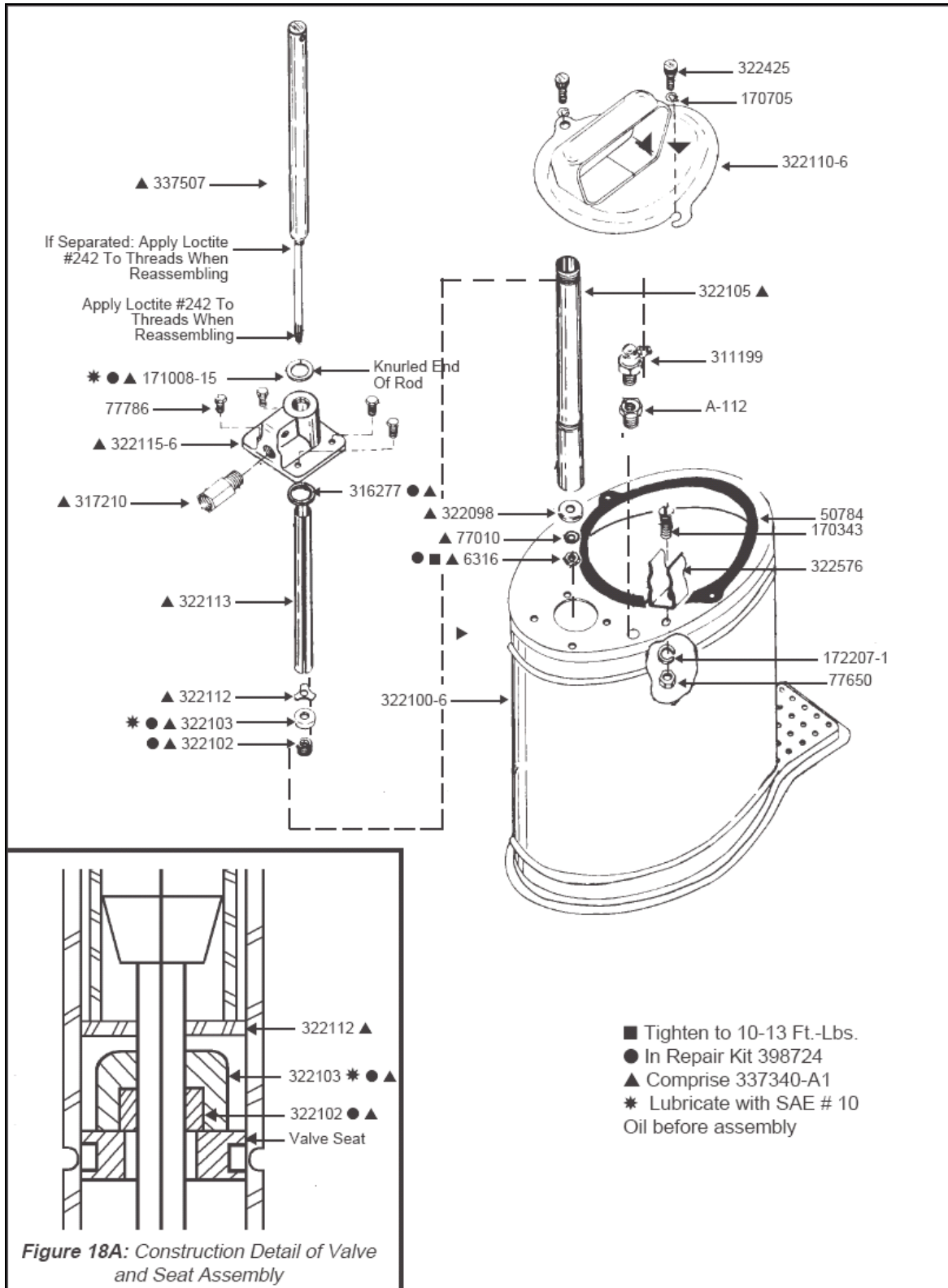

Figure 12: Components of Bucket and Pump Assembly for Series 7149-4 Bucket Pumps

SERVICE

DISASSEMBLY (Figures 2 and 12):

1. Remove wing nut 79882 from stud 322423 and remove stud from lever 322418-2 and plunger 337417-1.
2. Remove cotter pins 172212-14 and pins 322109-2 from lever and link 322092-7, allowing lever and link to be removed.
3. Unscrew knobs 322425 and remove cover 322110-6.
4. If gasket 50784 is to be replaced, pull off gasket and scrape mating surface of container 322100-6 clean. When reassembling, gasket should be cemented to container with suitable gasket cement.
5. Remove check valve 317210 from pump body 322115-6.
6. Unscrew four hex head cap screws 77786 and remove pump assembly from container.
7. Remove nut 6316, lockwasher 77010 and cup 322098 from Rod 337418.
8. Unscrew pump tube 322105 from pump body and remove aluminum gasket 316277, stop tube 322113, washer 322112, valve 322103 and sleeve 322102 from rod. Note that the end of stop tube with four holes goes nearest the pump body.
9. Pull plunger and rod up from pump body and remove rubber quad ring 171008-15 from groove in bore of pump body. Handle carefully to avoid scratches or nicks on plunger or bore of pump body.

REASSEMBLY:

To reassemble, reverse the above procedure while being certain that plunger, quad ring, valve and sleeve are well lubricated with light grease, and that the valve and quad ring are not damaged during installation.

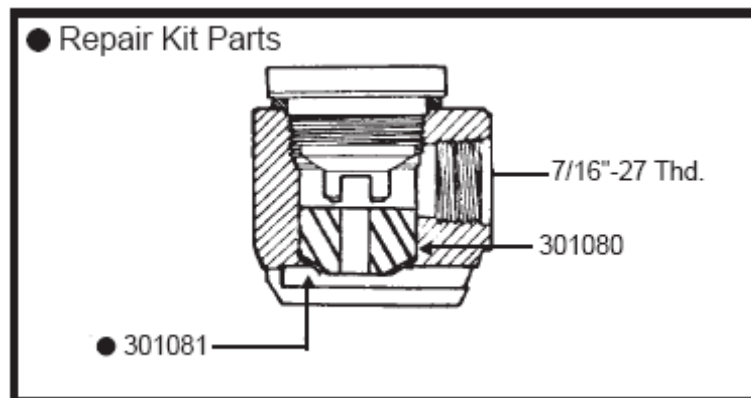

Figure 13: Model 42030 Standard Button-Head Coupler

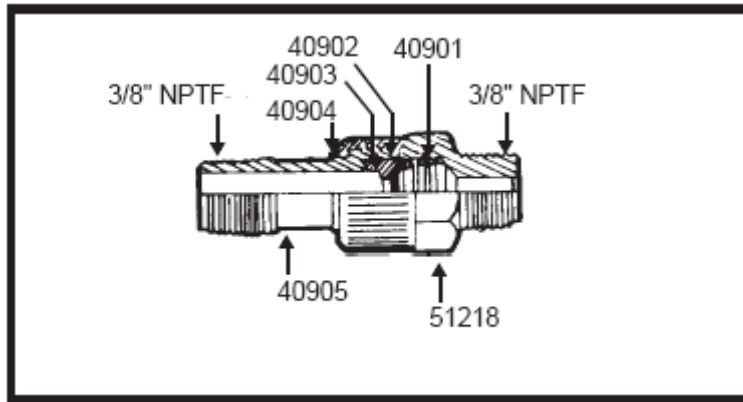

Figure 14: Model 51219 Hose Swivel

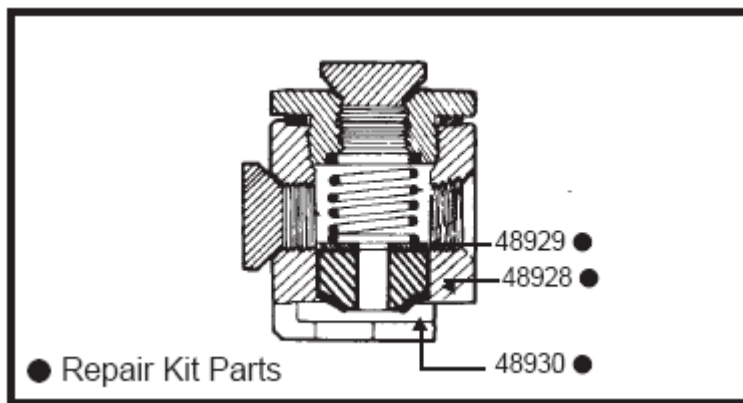

Figure 15: Model 304300 Giant Button-Head Coupler

Major Repair Kit

398724 For 7149-4 Series Bucket Pumps

Part No.	Description	Quantity
171008-15.....	Quad Ring, 3/4" I.D. x O.D.....	2
172212-14.....	Cotter pin, 3/32" x 5/8" long.....	3
316227.....	Aluminum Gasket, 1-1/16" O.D.....	1
322102.....	Sleeve.....	1
322103.....	Valve.....	1
6316.....	Nut, Hex, 5/16" - 24.....	1

Minor Repair Kits

398726 For 304300 Giant Button-Head Coupler (Figures 8, 15)

Part No.	Description	Quantity
48928.....	Rubber Seal, 11/16" O.D.....	10
48929.....	Flat Washer, 11/16" O.D.....	10
48930.....	Cone Washer,, 11/16" O.D.....	10

398727 For 42030 Standard Button-Head Coupler (Figure 7, 13)

Part No.	Description	Quantity
301080.....	Rubber Seal, 9/16" O.D.....	10
301081.....	Flat Washer, 9/16" O.D.....	10

PARTS LIST - Model 7149-A4 Bucket Pump (Figure 4)

Part No.	Description	Quantity
7149-4*.....	Bucket Pump Assembly.....	1
308730-A#.....	Hydraulic Coupler.....	1
317853-5#.....	Hose.....	1
322434.....	Hose Assembly (Figure 4).....	1

*See separate parts list
 #Included in Hose Assembly 322434

PARTS LIST - Model 7149-C4 Bucket Pump (Figure 5)

Part No.	Description	Quantity
6304-C#.....	Hydraulic Coupler.....	1
6617-G.....	Hose and Coupler Assembly (Figure 5).....	1
7149-4*.....	Bucket Pump Assembly.....	1
52940#.....	Adapter.....	1
317854-5F#.....	Hose.....	1

*See separate parts list
 #Included in Hose Assembly 6617-G

PARTS LIST - Model 7149-D4 Bucket Pump (Figure 6)

Part No.	Description	Quantity
A-112.....	Bushing (Figure 3).....	1
A-336.....	Pin-Type Fitting.....	1
7149-4*.....	Bucket Pump Assembly.....	1
43706.....	Angle Body.....	1
50491.....	Coupler.....	1
171134.....	Plug Button.....	1
317854-5F.....	Hose.....	1

*See separate parts list

PARTS LIST - Model 7149-E4 Bucket Pump (Figure 7)

Part No.	Description	Quantity
A-1188.....	Button-Head Fitting.....	1
6616-G.....	Hose and Coupler Assembly (Figure 7).....	1
7149-4*.....	Bucket Pump Assembly.....	1
42030+.....	Button-Head Coupler (Figure 13).....	1
46405+.....	Check Valve.....	1
51219*+.....	Hose Swivel (Figure 14).....	1
171134.....	Plug Button.....	1
301080#^.....	Rubber Seal, 9/16" O.D.....	1
301081#^.....	Flat Washer, 9/16" O.D.....	1
317854-5F+.....	Hose.....	1

#Repair Kit Part
 *See separate parts list
 +Included in Hose and Coupler Assembly 6616-G
 ^Included in Button-Head Coupler 42030

PARTS LIST - Model 7149-F4 Bucket Pump (Figure 8)

Part No.	Description	Quantity
6615-G.....	Hose and Coupler Assembly (Figure 8).....	1
7149-4*.....	Bucket Pump Assembly.....	1
46405+.....	Check Valve.....	1
48928#^.....	Rubber Seal, 11/16" O.D.....	1
48929#^.....	Flat Washer, 11/16" O.D.....	1
48930#^.....	Cone Washer, 11/16" O.D.....	1
51219*+.....	Hose Swivel (Figure 14).....	1
171134.....	Plug Button.....	1
304300+.....	Giant Button-Head Coupler (Figure 15).....	1
317854-5F+.....	Hose.....	1
322108.....	Button-Head Fitting Plug.....	1

#Repair Kit Part

*See separate parts list

+Included in Hose and Coupler Assembly 6615-G

^Included in Giant Button-Head Coupler 304300 (Figure 15)

PARTS LIST - Model 7149-H4 Bucket Pump (Figure 9)

Part No.	Description	Quantity
7149-4*.....	Bucket Pump Assembly.....	1
306741+.....	Loader Valve.....	1
308730-A#.....	Rubber Seal, 11/16" O.D.....	1
317853-5#.....	Hose.....	1
322434.....	Hose Assembly (Figure 4).....	1
322630.....	Loader Kit.....	1
322989+^.....	Loader Adapter.....	1

*See separate parts list

#Included in Hose and Coupler Assembly 322434

+Included in Loader Kit 322630

^Not available as a separately purchased part

PARTS LIST - Model 7149-4 Bucket Pump Assembly (Figure 12)

Part No.	Description	Quantity
A-112.....	Bushing.....	1
50784.....	Large Oval Cork Gasket.....	1
77650.....	Hex Nut, 1/4-20.....	1
170343^.....	Screw, 1/4-20 x 7/16" long.....	1
170705.....	Retaining Ring.....	2
172207-1^.....	Lock Washer, 1/4" I.D.....	1
311199^.....	Hydraulic Fitting.....	1
322100-6.....	Shell Assembly.....	1
322110-6.....	Cover Assembly.....	1
322425.....	Knob.....	2
322576.....	Spring Clip.....	1
377340-A1*.....	Pump-Tube Assembly.....	1
#^.....	Lever and Link Assembly (Figure 2).....	1

*See separate parts list

^Not available as a separately purchased part

PARTS LIST - Model 337340-A1 Pump-Tube Assembly (Figure 12)

Part No.	Description	Quantity
6316^	Hex Nut, 5/16-24	1
77010^	Internal-Tooth Lock Washer, 5/16"	1
77786	Hex-Head Cap Screw, 1/4-20 x 1/2" long	4
171008-15~	Quad Ring, 3/4" I.D. x 1" O.D.	1
316277~	Aluminum Gasket, 1-1/16" O.D.	1
317210	Check Valve	1
322098	Cup	1
322102~	Sleeve	1
322103~	Valve	1
322105	Tube Assembly	1
322112	Three-Point Star Washer, 11/32" I.D.	1
322113	Tube	1
322115-6	Pump Body	1
337507	Rod Assembly	1

~Repair Kit Part

^Not available as a separately purchased part

PARTS LIST - Lever and Link Assembly (Figures 2 and 11)

Part No.	Description	Quantity
79882	Wing Nut, 5/16-18	2
172212-14~	Cotter Pin, 3/32" x 5/8" long	2
322092-7	Link	1
322109-2~	Pin, 1-9/16" long	2
322418-2	Lever	1
322423	Stud, 1-19/32" long	1

~Repair Kit Part

PARTS LIST - Model 51219 Hose Swivel (Figure 14)

Part No.	Description	Quantity
40901^	Spring	1
40902^	Retaining Washer	1
40903^	Leather Cup	1
40904^	Swivel Nut	1
40905^	Swivel Stud	1
51218^	Adapter	1

^Not available as a separately purchased part

NOTE: The parts listed in this instruction sheet are for reference identification in the instructions and illustrations. Some of them are not available as separate parts, and these are noted in the parts list. Standard items such as nuts, bolts, etc. should be purchased at a hardware store. Refer to the current parts price list and bulletins before ordering parts, and always give the part number, quantity, description, and model where used when ordering parts. Parts availability and prices are subject to change without notice.

